

FUMED METAL OXIDES



CABOT

creating what matters

CAB-O-SIL® Fumed Silica in Unsaturated Polyester Resins



Table of contents	PAGE NR
Introduction	2
Grades of CAB-O-SIL Fumed Silica	3
Thickening and Thixotropy	4
Factors Affecting the Performance of Fumed Silica	6
Loading	6
Dispersion	7
Shear Rate and Dispersion	8
Mixing Time	9
Mixing Equipment	9
Styrene Content	10
Polar Additives	10
Effects of Promoter	11
Resin Chemistry	11
Comparison with Functional Substitutes	14
Practical Suggestions	14
Packaging, Handling, Health and Safety	15

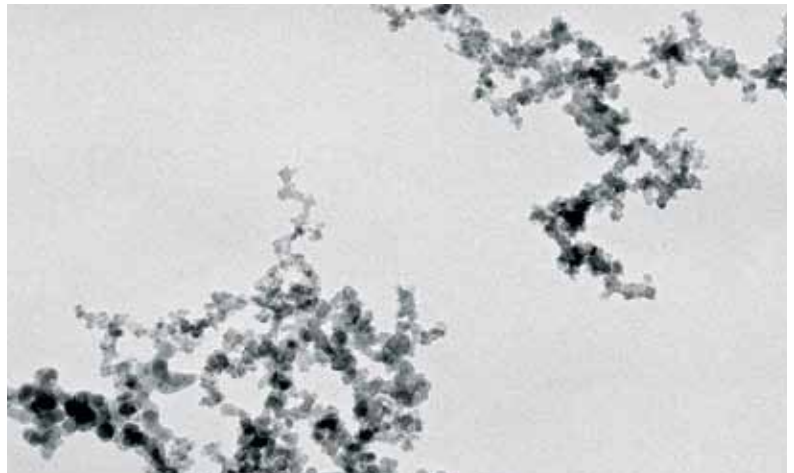

Electron photomicrograph of CAB-O-SIL HP-60 fumed silica at a magnification of 100,000X (from a negative print). The chain-like aggregates consist of fused spherical primary particles of pure silica.

Introduction

CAB-O-SIL fumed silicas have been employed as rheological control agents in a variety of liquid resin formulations. These control viscosity, thixotropy, flow, sag resistance, and sedimentation.

This brochure describes the use of CAB-O-SIL fumed silicas in unsaturated polyesters. Applications include laminating resins, gel coats, pastes, putties, tooling resins, adhesives and other formulations.

Brochure topics include grade selection, mixing and dispersion, the effect of various components on the particle network, and the regulatory status of CAB-O-SIL. Much of this information is applicable to vinyl ester resins as well as the various classes of polyester, and their blends.



Grades of CAB-O-SIL Fumed Silica

In the case of unsaturated polyester resins, the hydrophilic silicas are normally used and those silicas are generally of the 200 m²/g surface area. However, it is not unusual to find that silicas with higher surface areas may be used for certain formulations.

The general trend when incorporating fumed silica in organic resins or solvents is that more dispersing energy is needed to disperse a given amount of silica as the surface area increases. In other words, silicas with lower surface area are easier to disperse. In a fully dispersed system, lower surface area silicas require a higher weight loading in the resin than those of higher surface area to achieve similar viscosities and behaviors.

GRADES	TYPICAL PROPERTIES			
CAB-O-SIL untreated fumed silicas	Surface Area (m ² /g)	pH (4 % slurry)	Carbon Content (Wt %)	Loss on Heating (Wt % at 105° C)
HP-60	200	4.0	NA	< 1.5
M-5	200	4.0	NA	< 1.5
H-5	300	4.0	NA	< 1.5
HS-5	325	4.0	NA	< 1.5
EH-5	385	4.0	NA	< 1.5
CAB-O-SIL treated fumed silicas				
TS-720	115	-	5.4	< 0.6
TS-610	125	4.0 min	0.85	< 0.5
TS-530	225	5.5	4.25	-

Figure 1 shows the influence of BET-surface area (measured as m²/g) on the Brookfield viscometer at different tip speeds. In most organic systems, the general rule of thumb is silicas with higher surface areas are usually more difficult to disperse than those with lower values. However, if a higher surface area silica can be dispersed, it will have a more dramatic effect in the medium.

As seen in the graph, fumed silica of 200 m²/g (CAB-O-SIL HP-60) and 385 m²/g (CAB-O-SIL EH-5) behave differently at similar dispersion energies as indicated by the tip speed of the blade (a Cowles disperser was used in these studies). Fumed silicas with surface areas lower than 200 m²/g are also easier to disperse, but higher loadings are needed in order to achieve adequate results.

In general, 200 m²/g fumed silicas (CAB-O-SIL HP-60 and M-5) are used in polyester resins because they offer a good compromise between loading, dispersibility and desired viscosity. Higher surface area silica (smaller aggregate size) may be incorporated for specific results such as high clarity, when a higher degree of dispersion can be obtained.

Fig. 1: CAB-O-SIL HP-60 and EH-5 Dispersibility at 0.9% Concentration

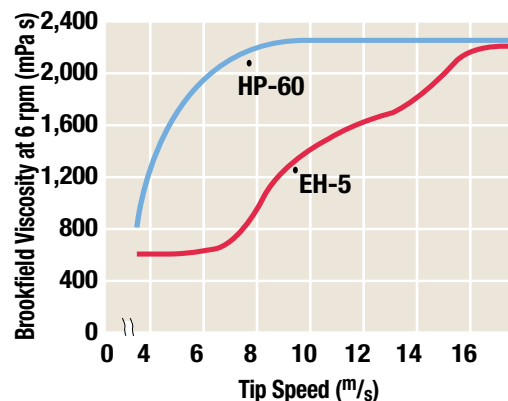

Thickening and Thixotropy

The surface of the fumed silica is made up of two types of chemical functionalities: siloxane and silanol groups. As in the case of organic compounds that contain hydroxyl functionality, the silanols have the ability to hydrogen bond with a number of functionalities including alcohol, carboxylic esters and acids, and other silanols.

The generally accepted mechanism for viscosity increase and thixotropic behavior is one where the silica aggregates interact to form an interpenetrating network as shown below. This network is determined by the surface characteristics of the silica and influenced by the characteristics of the resin.

As the silica is dispersed in the polyester resin, the agglomerates are broken down. When properly dispersed, these aggregates can interact and form an intermediate “chain” structure. Eventually, enough of these interact to form the desired network as the resin is allowed to stand. In essence, viscosity increases during this time period. When a shear force is applied to such a system, the network dissipates back to the individual chain structure, which results in a drop of viscosity. Upon standing, the network reforms and viscosity increases. Care must be taken because applying an excessive amount of dispersion energy may result in “over dispersion” with a loss of the thixotropic properties.

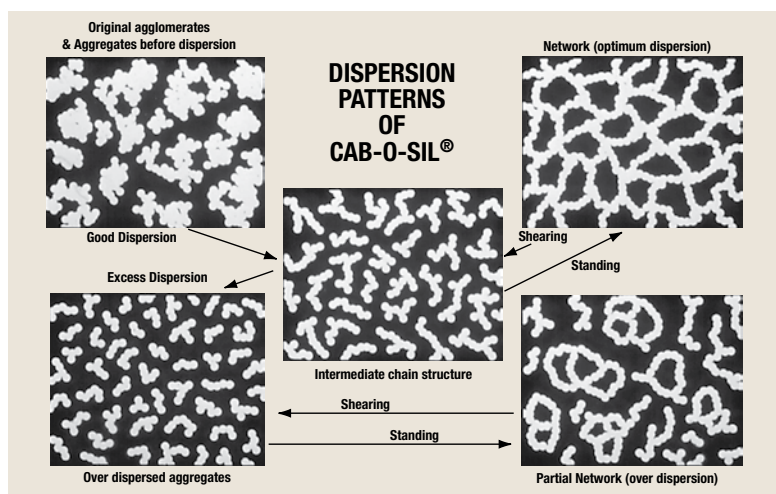

In reality, although the rheological properties imparted by fumed silica are based on a “network” being formed in the resin, the true system is not limited to the interactions of the aggregates with each other. The system also includes the interactions of the silica particles with the resin components, the polyester polymer and styrene, as well as the additives that help constitute the formulation. Hence, the real network that forms is more complicated than described here as one must take into account circumstances such as the polarity of the resin, the molecular weight of the polymer and the interactions of the polymer, styrene and additives.

As mentioned in the next section, there are a number of variables that can affect the performance of the final dispersion. In most cases, the standard CAB-O-SIL grades of 200 m²/g surface area, such as M-5 is sufficient. However, in an attempt to eliminate as much variability as possible, Cabot developed CAB-O-SIL HP-60. This silica imparts superior rheological behavior and stability over other base silicas as well as over competitive substitutes that are normally used in this area.

Figure 2 demonstrates this for two grades of CAB-O-SIL dispersed in a standard DSM Palatal® P4 resin, an unaccelerated orthophthalic product containing styrene. The Shear Thinning Index (STI) as measured by a Brookfield viscometer was monitored over time. STI is a popular means of characterizing the behavior of thixotropic polyester resins.

The terms “thix index” and “shear thinning index” are often used interchangeably. This is incorrect because the test method does not really consider the time-dependency of viscosity measurements. “Thixotropy” is the term used to refer to a shear thinning material whose behavior is time dependent. The term “shear thinning index” is therefore more appropriate when describing the ratio of the two Brookfield viscosities. The ratio is calculated by dividing two viscosity readings at two different spindle speeds, usually related 1:10, at a given temperature. Experience shows that sufficient thixotropy exists if the STI is on the order of 1.5 to 3 for laminating resins and 3 to 6 for gelcoats, measured at spindle speeds of, e.g., 5 and 50 or 6 and 60.

CAB-O-SIL HP-60 is very effective in a large number of orthophthalic (ORTHO) and isophthalic (ISO) unsaturated polyester systems including those made from blends containing dicyclopentadiene (DCPD) resins. Customers, as well as laboratory trials, indicate HP-60 is easy to handle, incorporate and disperse in polyester formulations. In addition, trials indicate CAB-O-SIL HP-60 reduces filter clogging by as much as 60% compared to other silicas. This is an indication that the product is easier to disperse.

CAB-O-SIL fumed silicas should be incorporated based on individual formulation needs and experience. Typical application methods suggest that the silica can be incorporated early into the base resin to increase the viscosity of the system. This increase in viscosity results in an increase of the shear forces that are needed for proper dispersion of the silica into the formulation. In many cases, the mixture is sheared until a specific, desired “grind” – as an indication of the extent of dispersion – is achieved. At this point, the other additives, as well as any required reactive diluent, can be added. The actual method of incorporation may vary depending on the specific formulation, dispersing equipment and customer specificity.

Fig. 2: Shear Thinning Index Aging Study of CAB-O-SIL (1.5%) in P4 Resin

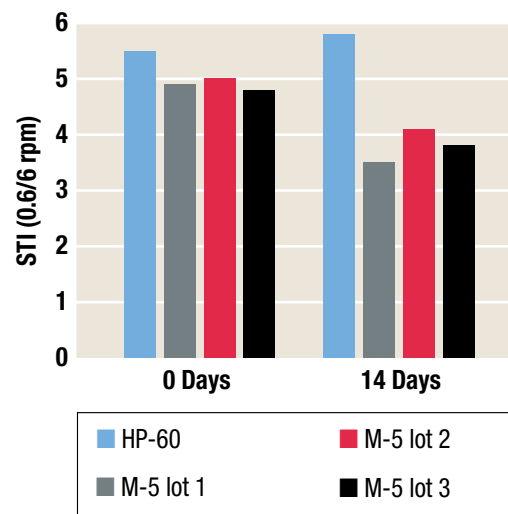

Factors Affecting the Performance of Fumed Silica



The incorporation of CAB-O-SIL fumed silica in polyesters is a function of a number of variables.

Several of the variables that can have an influence on the performance of the dispersion are:

- grade of fumed silica
- concentration of fumed silica
- dispersion condition (intensity, equipment, etc.)
- resin chemistry and molecular weight distribution
- styrene concentration
- free glycol content
- nature of the other additives used in a polyester resin formulation

Among the more predictable effects are those of silica grade, silica loading and dispersion conditions. The differences in behavior imposed by the resin chemistry and the presence of additives are complex, often making it impossible to draw any general conclusions. All of these factors should be considered when setting viscosity specifications for a particular product.

Loading

Pure laminating resins have too low viscosity and would drip-off the glass fiber mesh when applied. In order to compromise good wetting properties (viscosity as low as possible) and sufficient resistance to sag and drip, a concentration of around 0.8% of CAB-O-SIL fumed silica is typically used in the industry. Gel coats typically require 2.0 - 2.5% FS, or higher.

As seen in Figure 3, the higher the silica loading, the higher the viscosity. The shear thinning index will also increase. Increasing silica content results in a larger number of interactions between silica particles and hence higher apparent viscosity. The ability of the silica to form a network via these interactions results in the resin behaving as a thixotropic system.

Proper dispersion is essential to achieve the required specifications needed for applications of a thixotropic polyester resin. The conditions that affect dispersibility can vary greatly, but several can be more significant than others. Those are based on the energy needed to achieve the proper dispersion level or the shear force, the time needed to disperse the silica in the resin and the mixing or dispersing equipment used. A Cowles blade was used to generate the data in Figure 3 for 200 m²/g surface area fumed silica at a fixed dispersion time.

Fig. 3: Nature of Viscosity Development of CAB-O-SIL HP-60 Related to Dispersion Shear Rate and Concentration %

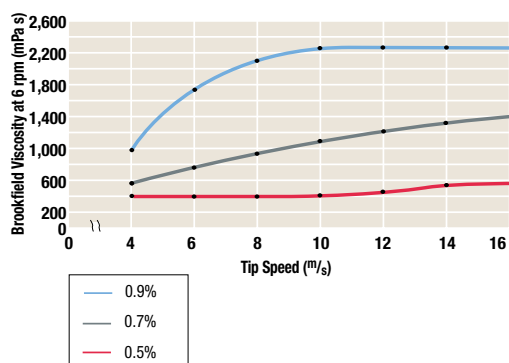

Dispersion

Figure 4 shows a typical viscosity profile as silica is dispersed in an unsaturated polyester resin over a given period of time. In such a process, the agglomerates are separated into much smaller fractions by the shearing force of the mixer. Optimization is usually reached when the viscosity begins to level as indicated by the “plateau” region of the graph. In this region, the dispersion is usually stable and can be maintained for extended periods. Theoretically, when the dispersion is optimized, the agglomerate is at its smallest distribution under the dispersing conditions. In many cases, this particle size can be indicated by measuring the Hegman grind of the formulation.

As mentioned earlier, there are a number of variables involved in this dispersion process that contribute to the time required to achieve this stable condition. Hence, depending on dispersing conditions and these variables, some resin formulations will require more or less time to reach the plateau.

Several types of dispersing equipment are used for achieving the described process. These include the Cowles Disperser, Ultrasonic Homogenizer, In-line Rotor-Stator and the Ystral Disperser.

Polarity of the media is an important aspect in the course of dispersing fumed silica. Extremes in polarity can affect the amount of silica that may be needed in a formulation, as well as the performance of that silica. Figure 5 demonstrates this by showing the effect of a given silica loading in three systems which range from a highly polar system based on hydrogen bonding to a non-polar matrix. It is believed polar systems disrupt the particle interactions with each other and thus cause a failure in the network associated with the silica. On the other hand, such interactions can also exist in the non-polar systems. The graph below is based on interactions with neat solvents such as an alcohol or a mineral oil, respectively. In reality, a polyester formulation is more complicated because of all the ingredients that can affect such polarities. However, as a general rule, most of these resins themselves, as well as the complete formulation, fall into a region of partial polarity as represented by the medium hydrogen bonded area of the graph.

Insufficient dispersing energy can result in poor performance. In some cases, depending on the resin, low viscosity can result. The benefit of having enough dispersing energy is: it gives a good balance between proper viscosity and particle size, as depicted in Figure 6. Viscosity requirements can vary based on specific applications or formulations, but the agglomerate size as measured by the Hegman grind needs to be sufficiently small in order to produce a stable dispersion. In general, large particles may result in problems with settling. Although there is not a set rule, grinds of less than 50 microns are needed for most applications.

Fig. 4: Dispersion of CAB-O-SIL Fumed Silica in Polyester Resin

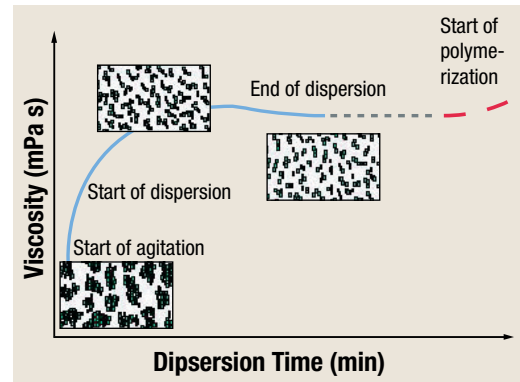
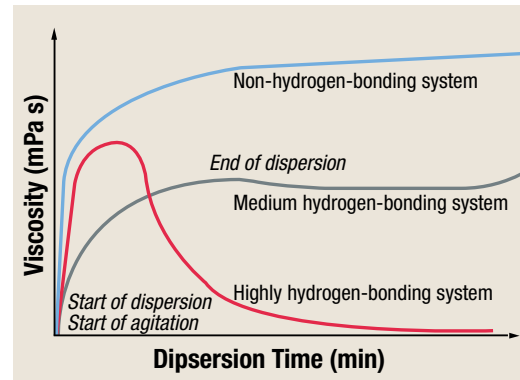

Fig. 5: Dispersion of CAB-O-SIL Fumed Silica in Systems of Different Polarity



Shear Rate and Dispersion

Figure 6 also shows that by varying the energy, as measured by the tip speed of the blade on the Cowles disperser, stable viscosity and lower particle size can be achieved when using different silica.

In some cases, due to different resin chemistries and dispersing factors, it is possible to “over disperse” fumed silica in unsaturated polyester resins and obtain less than optimum (stable) viscosity. Hence, it is recommended that profiles as depicted in graphs such as Figure 7 be used to optimize conditions.

Fig. 6: CAB-O-SIL HP-60 and Competitive A (200 m²/g)
(1.5% Fumed Silica at 5 min Dispersion Time)

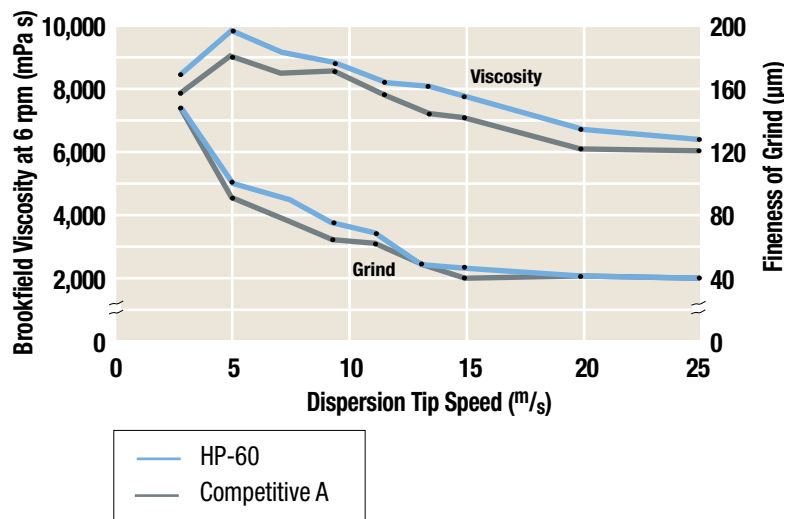

However, in the production of thixed laminating resins, two factors work against obtaining sufficient dispersion: the batch sizes are larger and the silica loading is lower. This size difference compared to gelcoat production makes it very impractical to do the dispersing in the large tank because the horsepower-to-volume ratio would be too low.

To overcome this problem, most manufacturers of thixed laminating resin use in-line dispersing devices where the resin is circulated through the disperser and back to a larger tank. The best known commercially available devices force the resin through a tiny orifice at high pressure where the resin stream hits a blade vibrating at ultrasonic frequency.

Insufficient dispersion can lead to all sorts of production headaches. If a viscosity is too low, the operator may try to compensate for it by adding more fumed silica, requiring additional dispersing time. In another scenario, the viscosity and shear thinning index may be in-specification, but the act of transferring through a gear pump means additional dispersing, which could result in an unexpected higher final viscosity. Poor dispersion should be avoided at all costs in both laminating resins and gel coats, to insure optimum rheology, flow control and stability.

Grindometer

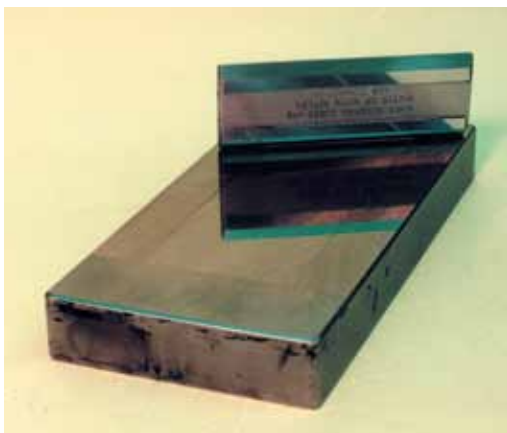

Mixing Time

As mentioned earlier, dispersion time can vary tremendously depending on variables such as equipment, formulation and batch size.

Figure 7 demonstrates that extending the mixing time during the dispersion step results in lower Hegman grinds and a stabilization of viscosities.

Mixing Equipment

Figure 8 compares the performance of various types of dispersion equipment. Ultrasonic homogenizers (sonolators) show the highest dispersion energy at constant conditions for a given fumed silica concentration.

Because the optimum adjustments and numbers of passes thru an ultrasonic disperser is critical and on-line batch corrections are difficult, many manufacturers still use the relatively simple dissolver disc.

To minimize variability, the following hints are useful for scale-up. The major difficulty with mixing vessels (using, for example a Cowles dissolver) is keeping production conditions, such as shear rate, filling height of resin, temperature profile during dispersion process and ratios of equipment dimension, as constant as possible.

In order to avoid scale-up problems translating lab results to the shop floor, the following ratios of dimensions should be respected:

Operating Conditions for Cowles Type Mixers (*Disc Position for Good Dispersion*)

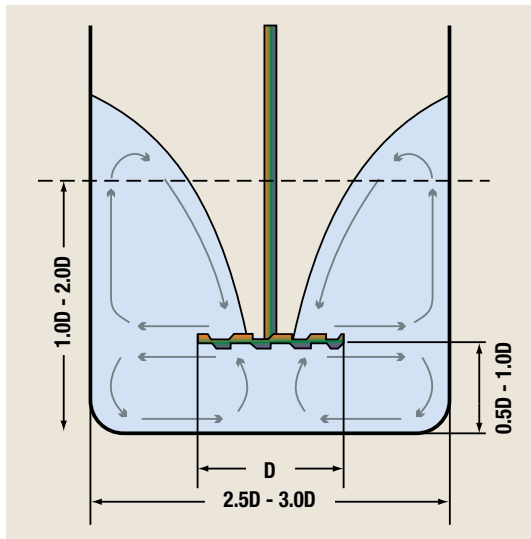

The determining factor of the mixing device is the diameter of the stirrer blade (D) which fixes the relation of all the other dimensions as depicted above.

Fig. 7: CAB-O-SIL HP-60 and Competitive A (1.5% Fumed Silica at 7m/s Tip Speed)

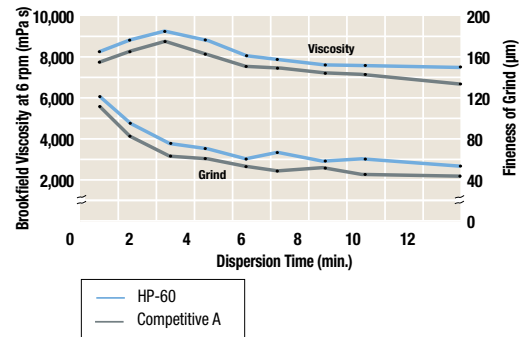
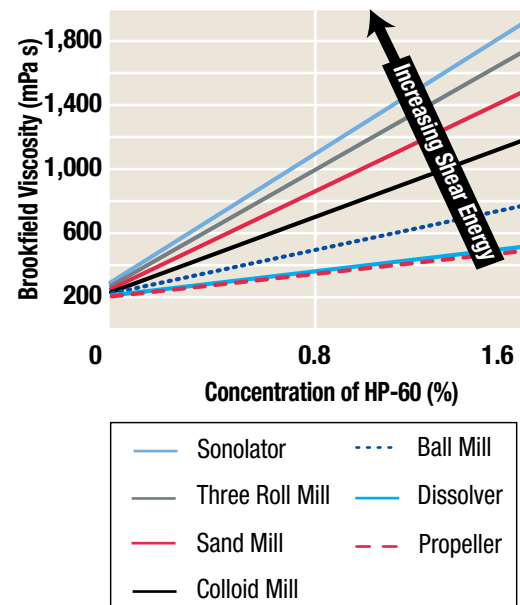

Fig. 8: Viscosity of CAB-O-SIL Thixed Polyester Resin Using Different Dispersion Equipment



Calculation of Tip Speed (peripheral speed)

General Formula:

$$\text{Tip speed (m/s)} = \text{disc } D \text{ (m)} \times \pi \times \frac{\text{rpm}}{60}$$

Example

Given:

600 rpm and disc diameter 0.3 m

Tip speed (m/s) calculated as follows:

$$\text{Tip speed (m/s)} = 0.3 \text{ m} \times 3.14 \times 600 \text{ rpm} / 60 = 9.4 \text{ m/s}$$

Styrene Content

Fig. 9: Thickening Efficiency of Fumed Silica (1.5%) in DCPD Resin at Different Styrene Concentrations

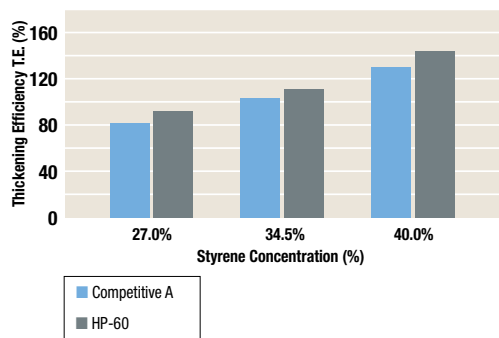

It is helpful to establish a measurement that quantifies the effectiveness of a given fumed silica as a thickener. Cabot uses an internal measure of thickening efficiency that compares the viscosity of a certain loading of fumed silica in a resin at a defined temperature, to that of a standard batch of fumed silica dispersed identically. This ratio, expressed as a percentage, is defined as the T.E.

Figure 9 shows that the T.E. increases as the concentration of the relatively non-polar styrene monomer concentration increases. This can be explained by the lower polarity and degree of particle-resins hydrogen bonding that accompanies the rise in styrene resulting in stronger particle-particle interactions, which strengthens the network.

Polar Additives

CAB-O-SIL Network After Optimum Dispersion and Additive Addition

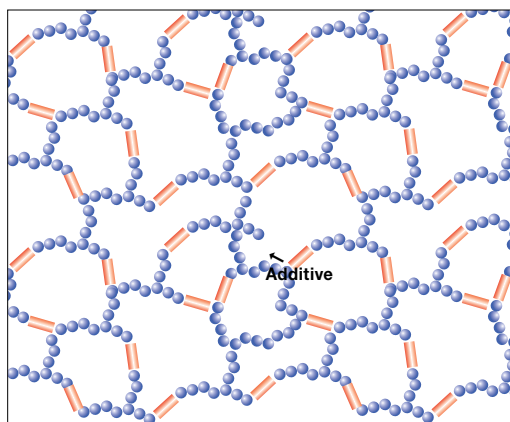

In order to boost the viscosity and improve the long-term stability of laminating resin formulations, additives at a concentration of 7-30% by weight of fumed silica are usually added during the final step of the manufacturing process. These polar additives consist mostly of glycols and non-ionic surfactants of various molecular weights, which can range from simple ethylene glycol to larger propylene glycols with molecular weights of 750. The actual materials and the amounts used are a function of both formulation and customer specifications.

The mechanism by which the additives function depends on the particular material used. Glycerin, glycol, and other polyhydroxyl compounds have multiple hydrogen bonding sites which allow them to act as “bridging agents” between fumed silica aggregates. This bridging strengthens the silica network, resulting in increased viscosity.

Effects of Promoter

All the discussion so far has been directed toward data generated in unpromoted pure polyester resins. It is common practice to provide the laminating resin with the promoter already added to it. The promoter might, however, affect the viscosity of the final product. It is quite evident that the presence of cobalt naphthenate (or octoate) could influence the viscosity of the thixed laminating resins, depending on the silica loading. At the higher silica loading of 2.0% in gelcoats, the effect of the promoter is to decrease the viscosity. At the lower silica loading of 0.8% in laminating resin formulations, the promoter does not have a significant effect.

Evidently, the promoter's bonding capability might interfere with the silica network formation. This effect is clearer at the higher silica loading because there is more of a silica network to interfere with.

Resin Chemistry

Unsaturated polyester resins have been in production since the 1940's and have been used in composite formulations for more than sixty years. Unsaturated polyesters are generally produced when a dicarboxylic acid or anhydride reacts with a glycol at elevated temperatures. An example is the reaction of orthophthalic anhydride, maleic acid and propylene glycol to produce a polymer of a desired molecular weight. This polymer is then dissolved in styrene, the reactive diluent, to produce the final resin.

Typical resins in the composites industry are indicated by their common names of ORTHO, ISO or DCPD. These names refer to resins using phthalic acid (commonly specified in this industry as orthophthalic acid), isophthalic acid or dicyclopentadiene, respectively, as their base or starting component.

The complicated aspect of DCPD resins is these materials are used as blends primarily with ortho resins. These blends can range anywhere from as high as 80% by weight DCPD and 20% ortho (in a resin blend) to the opposite ratio. As stated above, many of these are actually referred to as ortho resins. Hence, as an example, an ortho resin can be a material that is a blend of DCPD and ortho with both portions containing various amounts of maleic acid.

In this section, the performance of a sample of fumed silica was tested in different resins; variations are usually due to differences in resin chemistry. Parameters affecting the performance of fumed silica are styrene content, hydroxyl number, acid number and molecular weight. The relative amounts of backbone constituents such as phthalic anhydride, isophthalic acid, maleic anhydride, propylene glycol, etc., are also important. An exhaustive description of resin chemistry effects on fumed silica performance is clearly beyond the scope of this brochure.

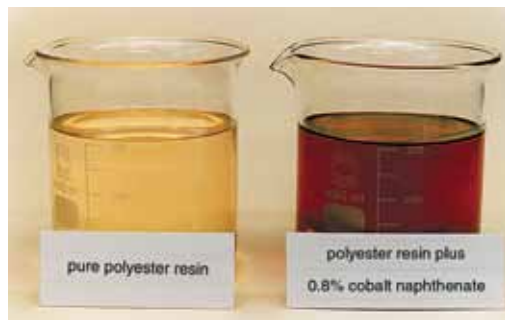

The photo above demonstrates the tinting effect of promoters, differentiating pure resins from pre-accelerated ones.

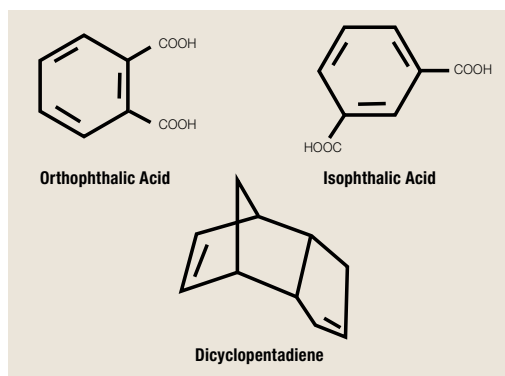

Based on specifications and needs, the resins are produced to a determined molecular weight. The proper amount of acid or anhydride and glycol are then mixed, under a variety of conditions depending on final properties, and allowed to react. The hydroxyl number is checked at certain points during the process. The relationship is that as molecular weight increases, OH-number decreases. All resin producers who have been contacted have indicated they keep their molecular weight distribution narrow by allowing the polymer to reach the proper hydroxyl number.

At this point, differences in resins that have the same starting monomers will be discussed. For example, consider two resins based on orthophthalic acid and ethylene glycol; both have the same hydroxyl number of 100 but different acid numbers of 25 and 10, respectively. The indication is they have the same molecular weight and should behave the same in a given application.

However, the higher acid number of the first material indicates that more acid functional groups are present than in the second material. The resin with the higher acid number may need “more acid groups” for its specific application and using less will not give the same final results. Obviously, this is also true for the lower acid number resin. However, both of these materials would be described as an ortho resin.

How a hydroxyl number is reached is very important to a final application. As described above, adjustment is achieved with the addition of more reactants followed by further reaction. However, adjustment can also be achieved by “back-blending” lower molecular-weight polyesters or starting monomers into the resin. This is very common in other polyester materials as well as in the polyethers. This method is used when cost is an issue, as it is far easier to adjust a low OH-number by adding a monomer (inexpensive ethylene glycol, for example) with a much higher number. Of course, this results in a broader molecular-weight distribution and final properties are affected once again. In the previous example, an ortho resin with an OH-number of 100 can also be achieved by back-blending a low OH-number resin with a monomer.

Although back-blending can be an issue, the most desired method of OH-number adjustment is to add enough glycol and acid so the number will be higher than desired, and then to allow the reaction to continue. In the case of the acid number, however, enough acid monomer may be added after the OH-number is achieved to reach whatever specification is needed.

What all this means is that an ortho resin as named by a first supplier may be a polymer synthesized from orthophthalic anhydride, maleic anhydride and a glycol to a specific molecular weight; another ortho resin from a second supplier may be a polymer made from orthophthalic anhydride, maleic anhydride and possibly a different glycol. Therefore, all ortho resins are not alike and how silica interacts with one may not have the same effect on the other.



The situation has become even more complicated in recent years with the increasing importance of the DCPD resins. In this particular series, although these materials are labeled as cyclopentadiene resins, they are often mixtures and copolymers of the diene and esters from maleic anhydride.

The maleic anhydrides are added to provide polar groups to the resin backbone because the cyclopentadiene polymer by itself has none. A discussion of the production of dicyclopentadiene is not warranted at this time, but one must be aware that the products used in the polyester industry are in truth a mixture of dicyclopentadiene oligomers and the oligomer ratio can vary in its overall composition. Using an ortho resin as an example, the resin named by a supplier can in fact be a mixture of any ortho resin as discussed earlier, and a mixture of a DCPD polymer as synthesized and described above.

Resin chemical composition is often a very significant factor in the long-term aging behavior of a fumed silica dispersion (Figure 10).

With the silica loading typically used in these kinds of applications, the time dependence of the viscosity is not well understood, and accurate characterization of it is beyond the capacity of the Brookfield viscometer. What appears to happen is the thixated resin recovers most of its viscosity almost instantly after agitation and the remainder is recovered more slowly. Aging data of dispersions shows a fairly consistent tendency for the Brookfield measurements. The exact behavior varies from resin to resin. Presumably, the fumed silica network formation is a process that requires several hours to reach its equilibrium. This can be a frustrating phenomenon for production personnel because a batch of thixated resin can be “in specification” when made and too high in viscosity the next day.

Longer-term ambient aging over four weeks will generally result in additional increases in viscosity for most polyesters. The main reasons for the viscosity increases observed here are further formation of the silica network and partial polymerization of the resin.

Fig. 10: Shear Thinning Index Aging Study of CAB-O-SIL HP-60 (1.5%) in Different Ortho Resins

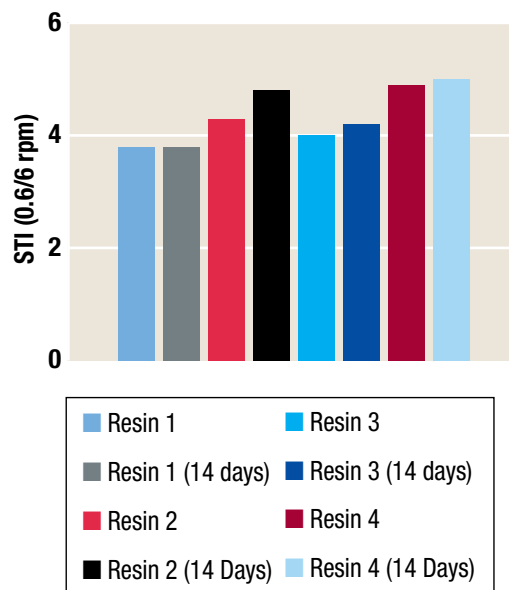

Comparison with Functional Substitutes

A comparison of viscosity built-up in unsaturated polyester resins that contain fumed silica and precipitated silica is depicted in Figure 11. HP-60 is the best choice; however, 1% of fumed silica always outperforms 3% of precipitated silica in orthophthalic resin DSM Palatal® P4 over the test period of 12 days.

Fig. 11: Viscosity of Fumed Silica (1%) vs. Precipitated Silica (3%) vs. Time

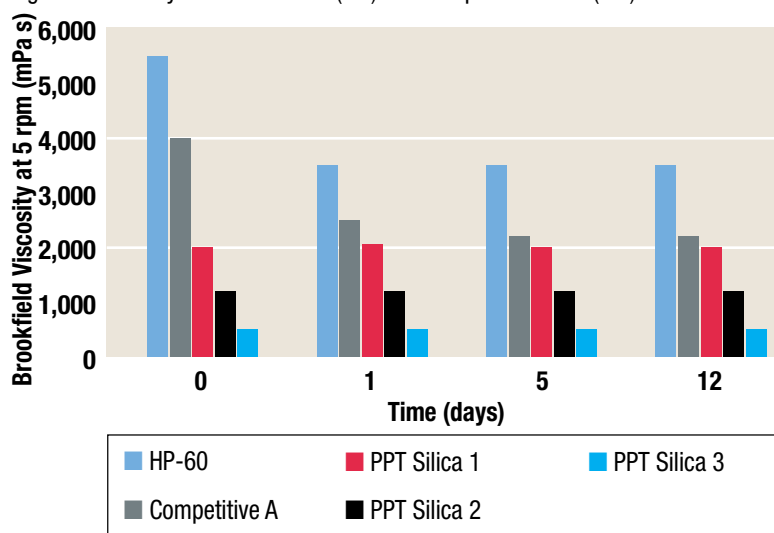

Practical Suggestions

Below is a summary of some key factors of thixotropic unsaturated polyester resins which could help the manufacturer of gelcoats and laminating resins when troubleshooting:

1. Sedimentation/settling results from insufficient dispersion and/or low concentration of thixotrope.
2. Appropriate batch scale-up, tip speed calculation and the right volume/horsepower ratio are critical for optimum dispersion.
3. Optimum fumed silica concentration and degree of dispersion (optimum fumed silica network) guarantees maximum viscosity and thixotropy.
4. Additives such as ethylene glycol, polypropylene glycol MW 720-750, Tween™ 20 (Uniqema), BYK®-A-555 and R-605 (Byk-Chemie) enhance and stabilize system rheology and help to release air bubbles.
5. Grindometer readings of <math><50\ \mu\text{m}</math> are generally suggested, which indicates nearly complete dispersion. However, somewhat higher readings may yield higher viscosity, while readings of 15-40 μm will give best anti-settling, anti-sag, clarity, and stability. Experimentation should always be done in the system of interest. Gelcoats often require finer grinds than laminating resins.

Packaging, Handling, Health and Safety

■ Packaging

CAB-O-SIL fumed silicas are currently available in a wide variety of packages including multi-layer paper bags, semi-bulk (e.g., big bag) and bulk containers.

■ Personal Health and Safety

Colloidal, amorphous, fumed silica can cause very mild if any eye and skin irritation. In the event of skin contact, the affected area should be washed with water. For eye contact, immediately flush with plenty of water for 15 minutes and seek proper medical attention.

For additional information, contact the nearest Cabot office.

■ Handling

Refer to our latest handling brochure Handling of CAB-O-SIL Fumed Silicas.

■ Regulatory Status

The Chemical Abstract Service (CAS), a division of the American Chemical Society, has issued CAB-O-SIL fumed silica the registration number 112945-52-5 (silica, amorphous, fumed, crystalline-free), which is recognized worldwide.

The EINECS No. for Europe is 2315454.

CAB-O-SIL fumed silica is included in the Toxic Substance Control Act (TSCA) inventory as CAS registry number 7631-86-9, which identifies silica (SiO₂) regardless of its physical form.

Continued excessive inhalation of concentrations above the 8-hour Threshold Limit Value-Time Weighted Average (TLV-TWA) of 10 mg/m³ for Particulates Not Otherwise Classified (PNOC) recommended by the American Conference of Governmental Industrial Hygienists (ACGIH) for synthetic amorphous fumed silica crystalline-free should be avoided.

The MAK value (maximum concentration at the workplace) in Germany for fumed silica is currently (1998) limited to 4 mg/m³ total dust during an exposure time of 8 hours.

Addresses

North America

Cabot Corporation
Business and Technical Center
157 Concord Road
Billerica, MA 01821-7001
USA
Tel: +1 978 663 3455
Tel: 800 462 2313 (*Technical Service*)
Fax: +1 978 670 7035
Tel: +877 225 5892 (*Customer Service*)

South America

Rua do Paraíso, 148 - 5th floor
Paraíso CEP 04103-000
SP São Paulo
BRASIL
Tel: +55 11 2144 6400
Fax: +55 11 3253 0051

Europe

Cabot
Interleuvenlaan, 15 i
3001 Leuven
BELGIUM
Tel: +32 16 39 26 59
Fax: +32 16 39 24 44

Middle East/Africa

Cabot Specialty Chem. Inc.
Jebel Ali Free Zone
LOB 15, Office 424 - PO Box 17894
Dubai
UNITED ARAB EMIRATES
Tel: +971 4 8871 800
Fax: +971 4 8871 801

China

Cabot (China) Limited
558 Shuangbai Lu
Wujing
201108 Shanghai,
CHINA
Tel: +86 21 5175 8800
Fax: +86 21 6434 5532

Notice and Disclaimer. The data and conclusions contained herein are based on work believed to be reliable; however, Cabot cannot and does not guarantee that similar results and/or conclusions will be obtained by others. This information is provided as a convenience and for informational purposes only. No guarantee or warranty as to this information, or any product to which it relates, is given or implied. CABOT DISCLAIMS ALL WARRANTIES EXPRESS OR IMPLIED, INCLUDING MERCHANTABILITY OR FITNESS FOR A PARTICULAR PURPOSE AS TO (i) SUCH INFORMATION, (ii) ANY PRODUCT OR (iii) INTELLECTUAL PROPERTY INFRINGEMENT. In no event is Cabot responsible for, and Cabot does not accept and hereby disclaims liability for, any damages whatsoever in connection with the use of or reliance on this information or any product to which it relates.

© Cabot Corporation, MA-U.S.A. All rights reserved 2010.

CAB-O-SPERSE®, CAB-O-SIL® and SpectraI® are registered trademarks of Cabot Corporation.

www.cabot-corp.com/Silicas-And-Aluminas



This brochure is printed on an FSC certified paper



CABOT

creating what matters